

CELLARCOOL

CellarCool
1738 E. Alpine Ave. Stockton, CA 95205
1(800) 343-9463
www.cellarcool.com

INTRODUCTION

The condensate pump kit is designed as an automatic condensate removal pump for water dripping off an air conditioner evaporative coil. The pump is controlled by a float/switch mechanism that turns the pump on when approximately 2-1/4" of water collects in the tank, and automatically switches off when the tank drains to approximately 1-1/4".

The pumps are carefully packaged, inspected and tested to insure safe operation and delivery. When you receive your pump, examine it carefully to determine that there are no broken or damaged parts that may have occurred during shipment. If damage has occurred, make notation and notify WhiskerKool. They will assist you in replacement or repair, if required.

READ INSTRUCTIONS CAREFULLY BEFORE ATTEMPTING TO INSTALL, OPERATE OR SERVICE THE LITTLE GIANT PUMP. KNOW THE PUMP APPLICATION, LIMITATIONS AND POTENTIAL HAZARDS. PROTECT YOURSELF AND OTHERS BY OBSERVING ALL SAFETY INFORMATION. FAILURE TO COMPLY WITH INSTRUCTIONS COULD RESULT IN PERSONAL INJURY AND/OR PROPERTY DAMAGE! RETAIN INSTRUCTIONS FOR FUTURE REFERENCE. INSTALLATION AND CONNECTIONS ARE TO BE MADE BY A QUALIFIED PERSON.



SAFETY GUIDELINE

DO NOT USE TO PUMP FLAMMABLE OR EXPLOSIVE FLUIDS SUCH AS GASOLINE, FUEL OIL, KEROSENE, ETC. DO NOT USE IN EXPLOSIVE ATMOSPHERES. PUMP SHOULD BE USED WITH LIQUIDS COMPATIBLE WITH PUMP COMPONENT MATERIALS.

DO NOT HANDLE PUMP WITH WET HANDS OR WHEN STANDING ON A WET OR DAMP SURFACE, OR IN WATER. THIS PUMP IS SUPPLIED WITH A GROUNDING CONDUCTOR AND/OR GROUNDING TYPE ATTACHMENT PLUG. TO REDUCE THE RISK OF ELECTRICAL SHOCK, BE CERTAIN THAT IT IS CONNECTED TO A PROPERLY GROUNDING TYPE RECEPTACLE.

IN ANY INSTALLATIONS WHERE PROPERTY DAMAGE AND/OR PERSONAL INJURY MIGHT RESULT FROM AN INOPERATIVE OR LEAKING PUMP DUE TO POWER OUTAGES, DISCHARGE LINE BLOCKAGE, OR ANY OTHER REASON, A BACKUP SYSTEM(S) AND/OR ALARM SHOULD BE USED.

SUPPORT PUMP AND PIPING WHEN ASSEMBLING AND WHEN INSTALLED. FAILURE TO DO SO MAY CAUSE PIPING TO BREAK, PUMP TO FAIL, MOTOR BEARING FAILURES, ETC.

INSTALLATION

1. Before installing pump, allow air conditioner to cycle several times, collecting condensate in a separate container to help flush any residual oils that may remain in the system.
2. Carefully unpack the pump. Remove the cardboard packing from the motor cover air slots. Carefully slide the packing away from the pump. This packing is used to prevent switch movement during shipment (Figure 1).

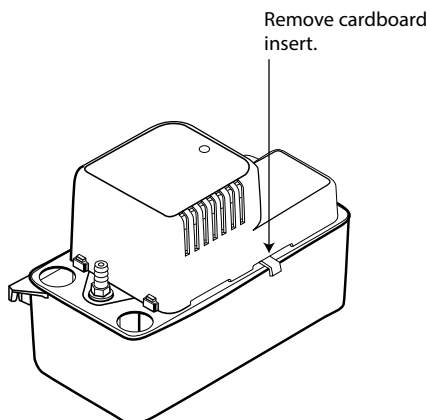

3. Mounting the pump: the tank has two slots provided to mount the unit. The slots are located on the ends of the tank (Figure 5). The unit should be mounted either on the side of the air conditioner unit or nearby wall. Pump must be level and the inlet must be below the coil drain. Conduit fittings are not compatible with the plastic pump housing.
4. The pump should not be installed in a manner that will subject it to splashing or spraying.
5. This pump is not intended for use inside air plenums.

ELECTRICAL CONNECTIONS



1. Shut off electrical power at fuse box before making any connections. All wiring must comply with local codes.
2. Line voltage: Connect power cord to line voltage specified on motor and nameplate. Power cord must be connected to a constant source of power (not a fan or other device that runs intermittently). If power cord does not have a plug, wiring is as follows: green (or green/yellow)—ground. Black (or brown)—line. White (or blue)—neutral.

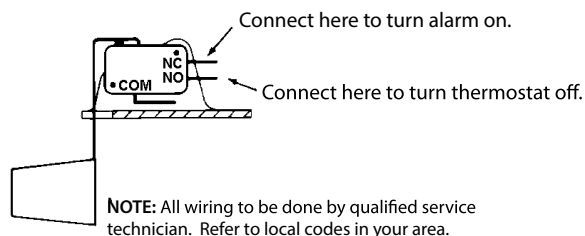

3. Safety switch: The safety overflow switch should be connected to a class II low voltage circuit. To control a thermostatic circuit the COM and NO connections from the safety switch are to be wired in series with the low voltage thermostat circuit to shut down the heating/AC circuit. The COM and NC switch contacts may be used to actuate a low voltage alarm circuit (connected in series) if the heating/cooling system can not be disrupted. The safety switch comes from the factory with leads connected to the COM and NO switch terminals. Typical hook-up of "NC" circuits would be (Figures 2 & 3).
4. If fused plug is used on 230V units, a 1.0 amp fuse is recommended.

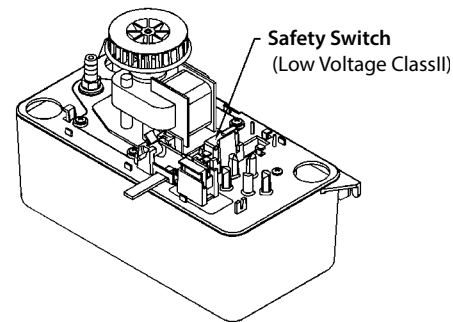

PIPING

1. Run flexible tubing or pipe from evaporator drain into one of the three pump inlets. Be sure inlet piping is sloped downward to allow gravity flow (Figure 4). Extend the inlet piping into the tank from 1 to 3 inches to ensure that it will not interfere with proper float operation. Be sure that the inlet piping is cut at an angle where it enters the tank.

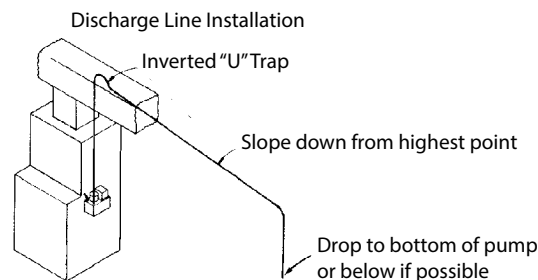

- The outlet piping should be flexible tubing secured with a hose clamp (not provided) or pipe (3/8 inch I.D. maximum to prevent excessive flow back to unit). From condensate unit, extend discharge piping straight up as high as necessary. Do not extend this line above the head/GPH of the particular model being installed. From this high point, slope discharge line down slightly to a point above drain area; then turn down and extend to a point below or approximately level with the bottom of the condensate unit. This will give a siphoning effect which will improve efficiency of the condensate unit and will, in most cases, eliminate the need for a check valve (Figure 5). If it is not possible to slope discharge line down, make an inverted "U" trap directly above the pump at the highest point.

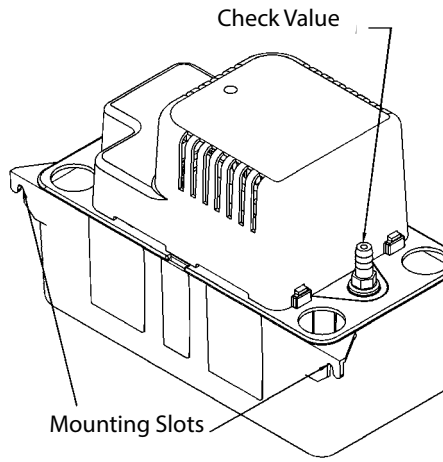

- Be sure the floats move freely. Clean as necessary (Figure 6).
- Clean the tank with warm water and mild soap.
- Check the inlet and outlet piping. Clean as necessary. Be sure there are no kinks in the line that would inhibit flow.

TESTING

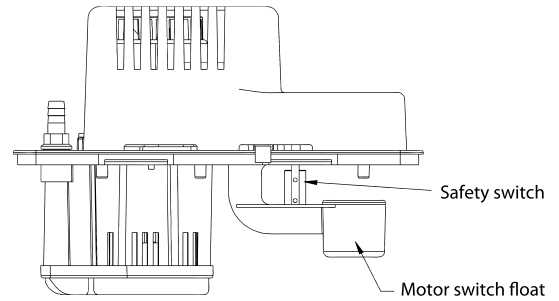

- Turn on power.
- Remove motor/tank cover assembly and hold level.
- Test motor switch by raising motor switch float with finger (Figure 6). Motor should turn on just before float contacts cover.
- Test safety switch by raising safety switch float with finger. Safety switch should activate before float contacts cover.
- Replace motor/tank cover assembly on tank. This pump is suitable for gas furnace condensate applications. Caution must be taken to ensure acidity of condensate does not increase below the average pH of 3.4 (to prevent localized pocket of acid that acts like a battery causing pitting) by routinely cleaning or flushing tank with fresh water.

SERVICE INSTRUCTIONS



- Make certain that the unit is disconnected from the power source before attempting to service or remove any component!

